



Prater Industries, Inc.

SuperTwin Spiral Mixers[®]

**Faster,
more thorough
mixing of
feed ingredients,
seeds and similar
free-flowing
materials**



BULLETIN NUMBER MX-83

Patented twin spiral design is the key to fast, thorough mixing.

The Prater SuperTwin Spiral Mixer® provides the feed processor with completely mixed batches faster than a single-auger mixer and at lower capital costs than a comparably sized horizontal mixer. Built by a leading supplier to the grain and seed processing industries, hundreds of SuperTwin mixers are operating in feed plants throughout the world.

PROVEN BY UNIVERSITY TESTS

A two-ton batch thoroughly blended in four minutes. That's the kind of results you can expect with a SuperTwin Spiral Mixer®. Tests conducted over a four-year period at the University of Kansas consistently produced finished feed batches in six minutes or less. The Prater SuperTwin, a model 12ST160, produced batches with additives evenly distributed throughout in an average of four minutes.

The two spirals mix faster and more thoroughly for two main reasons. The twin spirals provide more auger surface, and they operate at different speeds. This provides a three-way mixing action: vertically downward in the main chamber of the mixer, vertically upward in the inner mixing chamber and horizontally between the augers because of their difference in speed.



Speed difference between augers creates three-way mixing action.



LOWER COSTS FOR MIXING CAPACITY

This faster mixing action means more throughput per horsepower/hour. And more tonnage in a day. Plus, a SuperTwin requires less horsepower than a comparably sized horizontal mixer so with its lower initial cost, you get double savings and faster payback.

FOUR SIZES, FLOOR OR CEILING MOUNT

Prater offers four models of SuperTwin Spiral mixers. The chart below is a guide for selecting the model best suited for your requirements. Weights of the ingredients are only approximate and vary with every application.

All models are available in floor-mounted or above floor configurations. Ceiling mounted models are fed through openings in the top of the mixer body and require no below floor structures. Floor mounted models are fed

through a floor level inlet chute and are supplied with the floor intake and grate as standard equipment. Pit requirements are minimal. Both configurations can be erected in existing structures.

Model Number	Effective Capacity (Cu. Ft.)	Auger Size (Dia. In.)	TOTAL BATCH WEIGHT INCLUDING CONCENTRATES/ SUGGESTED MOTOR SIZE (HP)				
			Hay & Ear Corn	Ear Corn	Ear Corn & Oats	Shelled Corn & Oats	Shelled Corn
9ST50	50	9	—	—	—	1920/10	2400/10
12ST100	100	12	3000/7.5	3600/7.5	3000/7.5	3200/10	4000/10
12ST160	160	12	4800/10	5800/10	4900/10	5100/15	6400/15
14ST250	250	14	7500/20	9000/20	7500/20	8000/25	10,000/25

The Prater SuperTwin Spiral Mixer®

dimensions

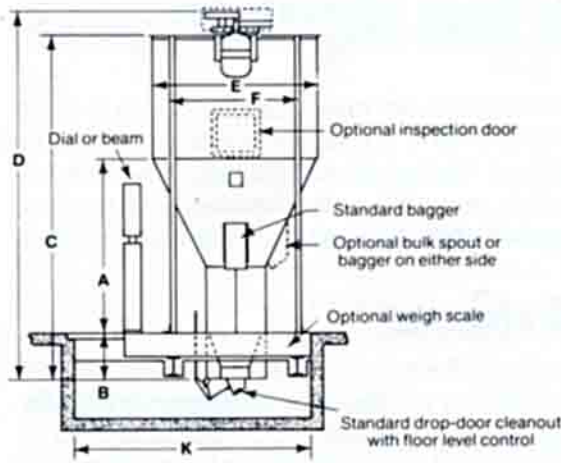

FRONT VIEW

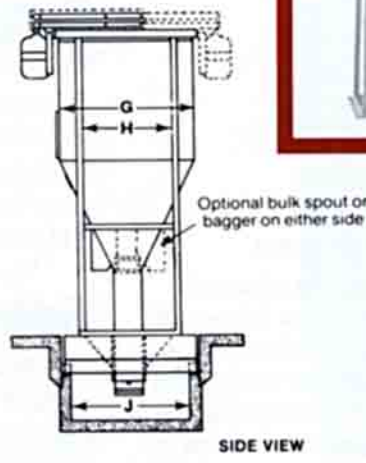

SIDE VIEW

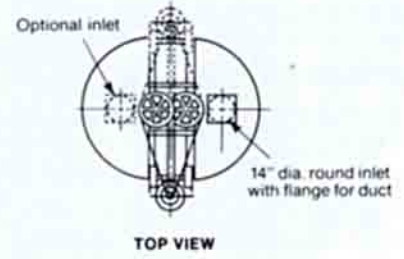

TOP VIEW



FLOOR MOUNTED

SIZE	H.P.	Dimensions (Inches)									
		A	B	C	D	E	F	G	H	J	K
12 ST 100	7½ 10	84½	24½	146½	155½	74½	59	61½	46	72	45
12 ST 160	10 15	84½	24½	168½	180½	74½	59	61½	46	72	45
12 ST 250	20	94	24½	185½	198½	87½	69	72	54	96	49

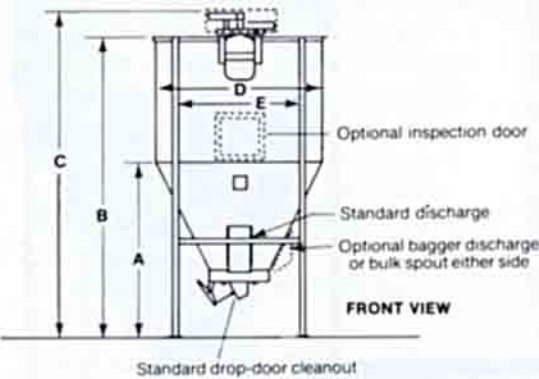

FRONT VIEW

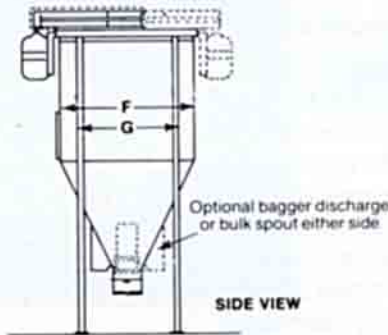

SIDE VIEW

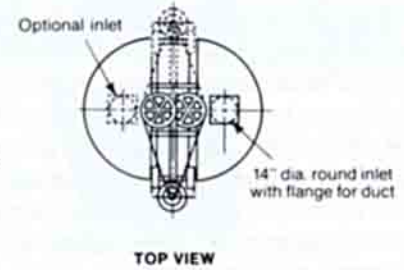

TOP VIEW

ABOVE THE FLOOR

SIZE	H.P.	Dimensions (Inches)						
		A	B	C	D	E	F	G
9 CST 50	5	45	77½	84	63	50	53	38
12 CST 100	7½ 10	84½	122	132	74½	59	61½	46
12 CST 160	10 15	84½	144½	156½	74½	59	61½	46



Prater Industries, Inc.

ONE OF THE ASSOCIATED PRATER COMPANIES

1515 South 55th Court / Chicago, Illinois 60650

Phone: 1-708/656-8500 / TELEX: 28-4312 / FAX: 708/656-8576

The Prater SuperTwin Spiral Mixer®

dimensions

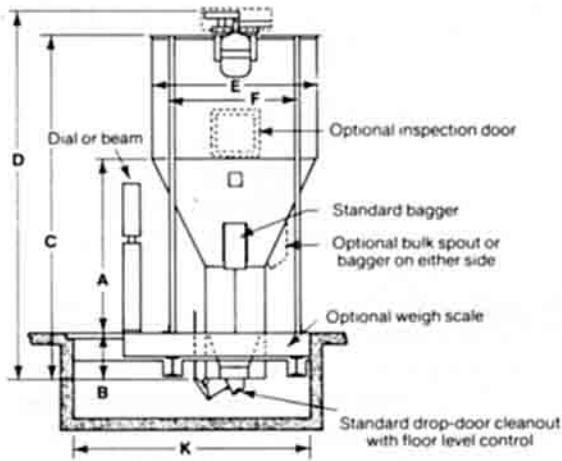

FRONT VIEW

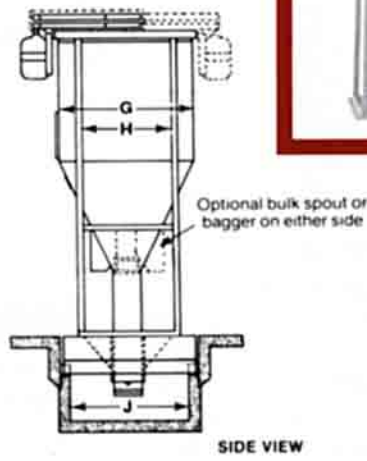

SIDE VIEW

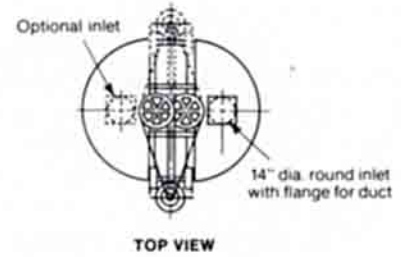

TOP VIEW



FLOOR MOUNTED

SIZE	H.P.	Dimensions (Inches)									
		A	B	C	D	E	F	G	H	J	K
12 ST 100	7½ 10	84¼	24¼	146½	156½	74¼	59	61¼	46	72	45
12 ST 160	10 15	84¼	24¼	168½	180½	74¼	59	61¼	46	72	45
12 ST 250	20	94	24¼	185½	198½	87¼	69	72	54	96	49

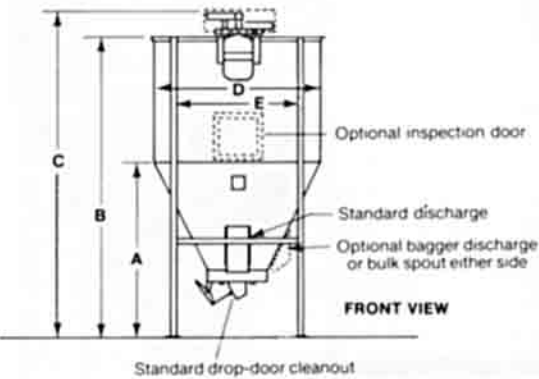

FRONT VIEW

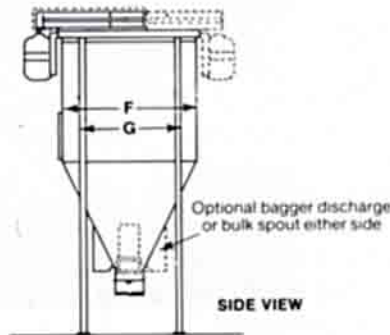

SIDE VIEW

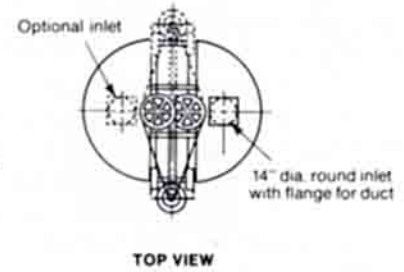

TOP VIEW

ABOVE THE FLOOR

SIZE	H.P.	Dimensions (Inches)						
		A	B	C	D	E	F	G
9 CST 50	5	45	77¼	84	63	50	53	38
12 CST 100	7½ 10	84¼	122	132	74¼	59	61¼	46
12 CST 160	10 15	84¼	144¼	156½	74¼	59	61¼	46



Prater Industries, Inc.

ONE OF THE ASSOCIATED PRATER COMPANIES

1515 South 55th Court / Chicago, Illinois 60650

Phone: 1-708/656-8500 / TELEX: 28-4312 / FAX: 708/656-8576